

DXWP1 & DXWP2 WEATHERPROOF OUTLET WEATHERPROOF SWITCHGEAR

Description

DXWP series surface switches are impact resistant and designed for general purpose outdoor applications like lighting control and illumination control where weather protection is necessary.



DXWP1

DXWP2

Features

- ✔ Compact Size of 86 x 86 x 65
- ✔ Large toggles ensure convenient ON-OFF switch operation
- ✔ Ample conduit entries in the base, 2 x 25mm plain, 2 x 20mm plain, 1 x 25mm and 1 x 20mm on each side of box as well as 1 x 25mm rear entry for back wiring.
- ✔ Separate switch wiring

Technical Parameter

- ✔ Standard: IEC60669-1, AS/NZS3133
- ✔ Rated Voltage: 250/440V AC
- ✔ Rated Frequency: 50/60Hz
- ✔ IP Protection: IP55/IP66

Approvals

CE, SAA

Overall & Mounting Dimensions

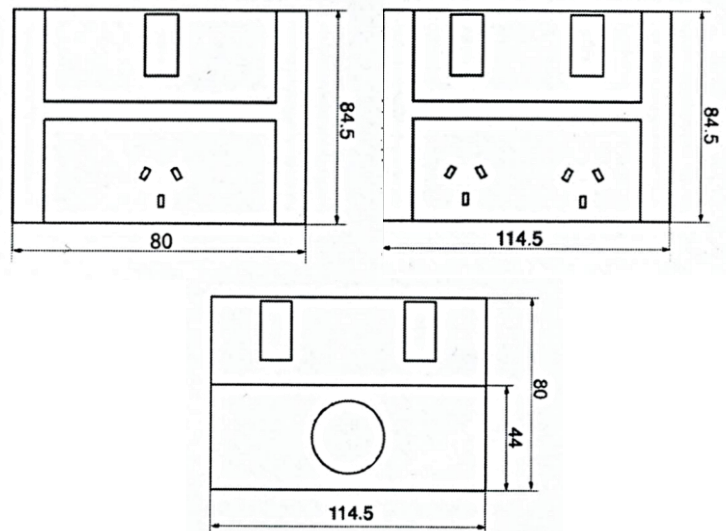

Specification

CAT No.	Rating (Amps)	IP Rating
DXWP1	10A	IP53
DXWP1/15	15A	
DXWP2	10A	
DXWP2/15	15A	